

MAIN FEATURES

EPLA is an absolute linear potentiometer assuring great reliability even in tough applications with heavy vibrations and shocks.

The groove on the enclosure of the transducer represents an excellent alternative to the usual system of fastening with brackets.

Installation is also made simpler by the absence of variations on the electrical output signal outside of the theoretical electrical stroke.

EPLA is the right solution in machinery for material processing such as injection presses for plastic, rubber and so on.



ORDERING CODE

EPLA 200 X 10 C5 A

SERIES
linear potentiometer model **EPLA**

STROKE
mm from **50** to **900**
see table for stroke availability

ENCLOSURE RATING
IP 60 **X**
IP 65 **S**

TRAVEL SPEED
max 10 m/s **10**

OUTPUT TYPE
cable (standard length 1 m) **P**
3 pin connector **C3**
DIN 43650-A 4 pin connector **C4**
DIN 43322 5 pin connector **C5**

OUTPUT DIRECTION
axial **A**

EPLA

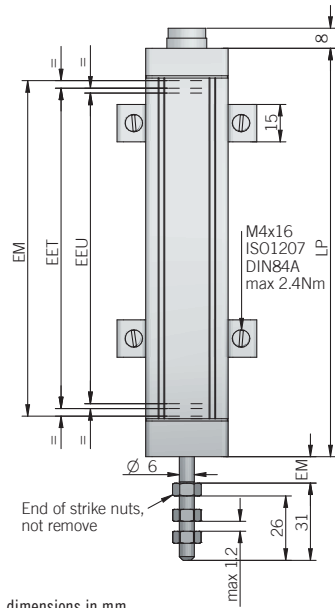
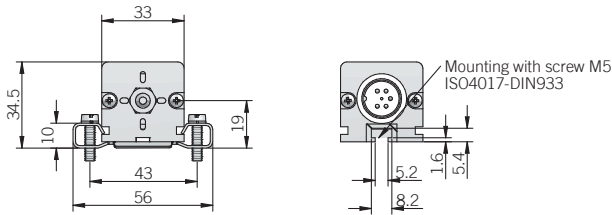

dimensions in mm

ELECTRICAL SPECIFICATIONS

Resolution	virtually infinite
Independent linearity	± 0,05 %
Repeatability	0,01 mm
Resistance tolerance	± 20 %
Recommended cursor current	< 0,1 µA
Resistance thermal coefficient	-200 ... 200 ppm / °C typical
Output voltage temperature coefficient	≤ 5 ppm / °C
Power dissipation	3 W at 40 °C / 0 W at 120 °C
Max cursor current	10 mA
Applicable voltage	60 V DC max
Electrical insulation	> 100 MΩ, 500 V DC, 1 bar, 2 s
Dielectric strenght	< 100 µA, 500 V AC, 50 Hz, 1 bar, 2 s
RoHS	according to 2015/863/EU directive

Important: data are valid if the transducer is used as a ratiometric device with a maximum applicable current ≤ 0,1 µA

MECHANICAL SPECIFICATIONS

Stroke	50 - 100 - 150 - 200 - 300 - 350 - 400 - 450 - 500 - 600 - 750 - 900 mm
Useful electric stroke (EEU) (+ 3 / - 0 mm)	see model (mm)
Theoretical electric stroke (EET) (±1 mm)	EEU + 3 mm (50 ... 150), EEU + 4 mm (200 ... 300), 355 mm (350), 406 mm (400), 457 mm (450), 508 mm (500), 609 mm (600), 762 mm (750), 914 mm (900)
Mechanical stroke (EM)	EEU + 9 mm (50 ... 150), EEU + 10 mm (200 ... 300), 361 mm (350), 412 mm (400), 463 mm (450), 518 mm (500), 619 mm (600), 772 mm (750), 924 mm (900)
Resistance (on the EET)	5 kΩ (50 ... 600) 10 kΩ (750 ... 900)
Case length (LP)	EEU + 63 mm (50 ... 150), EEU + 64 mm (200 ... 300), 415 mm (350), 466 mm (400), 517 mm (450), 572 mm (500), 673 mm (600), 826 mm (750), 978 mm (900)
Travel speed	10 m/s max
Acceleration	200 m/s ² max
Enclosure rating	X = IP 60 (IEC 60529) S = IP 65 (IEC 60529)
Shock	50 G, 11 ms (IEC 60068-2-27)
Vibration	20 G, 5 ... 2000 Hz (IEC 60068-2-6)
Displacement force	3,5 N typical (IP 60) / 15 N typical (IP 65)
Housing material	anodized aluminium / Nylon 66 G
Pull shaft material	1.4305 / AISI 303 stainless steel
Mounting	brackets with variable center-to-center distance or M5 ISO4017 - DIN933 screw
Life	> 25 x 10 ⁶ m strokes or > 100 x 10 ⁶ manoeuvres
Operating temperature^{1,2}	-30° ... +100°C (-22° ... +212°F)
Storage temperature²	-50° ... +120°C (-58° ... +248°F)

¹ measured on transducer

² condensation not allowed

Installation warning instructions:

- connect the transducer according to the reported connections
- DO NOT use it as a variable resistance
- the transducer calibration has to be done setting the stroke in order to have an output signal between 1 % and 99 % of the voltage level

CONNECTIONS

Function	Cable	3 pin C3	4 pin C4	5 pin C5
+	blue	3	3	3
-	brown	1	1	1
OUTPUT	yellow	2	2	2
NC	/	/	/	/
NC	/	/	/	/
⊖	shield	/	⊖	/

C3 connector (3 pin)

solder side view FV



C4 connector (4 pin)

DIN 43650-A solder side view FV

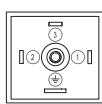

C5 connector (5 pin)

DIN 45322 solder side view FV

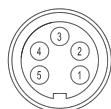

- fixing kit (brackets, screws) included
- female connector not included, please refer to Accessories

